

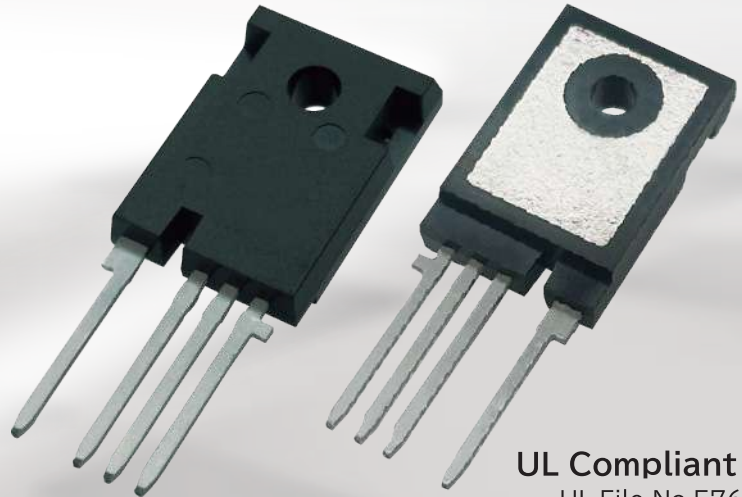

SiC MOSFET (TO-247-4L)

FMG50AQ170N6

50A 1700V SiC MOSFET
TO-247-4L Package (Isolated)

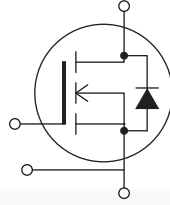

UL Compliant 
UL File No.E76102

Applications

- ▶ Industrial Inverters
- ▶ Switching Power Supplies
- ▶ High Frequency Power Supplies etc.

Features

- Isolated TO-247-4L package with high heat dissipation
- No additional FWD(Flywheel Diode) required
- High short-circuit withstand time capability
- Low on-resistance even at high temperatures
- High noise immunity

Advantages brought by DioMOS* technology

*SiC MOSFETs(DioMOS) with flywheel diode are mounted to maximize package space utilization, resulting in low RDS(on).

Low on-state resistance even at high temp.

ON Resistance temperature characteristics (normalized at 25 °C)

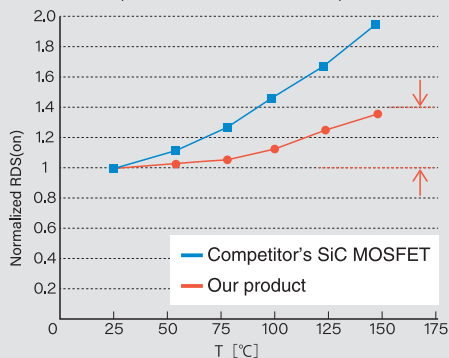

Built in FWD

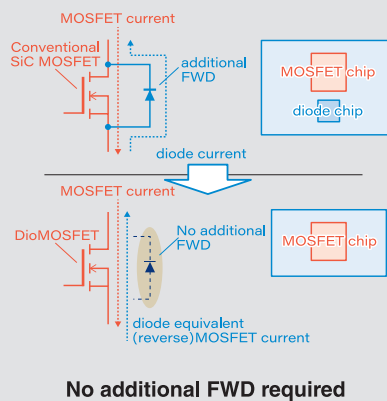

Supports high current density

The unique terminal structure reduces wiring resistance and provides strong bonding, bringing out SiC chips performance with a current density four times greater than in conventional products.

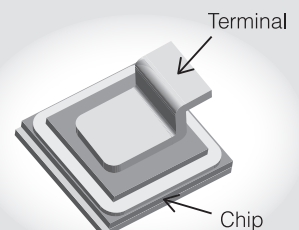

SiC MOSFET (TO-247-4L)

FMG50AQ120N6
 50A 1200V SiC MOSFET
 TO-247-4L Package (Isolated)

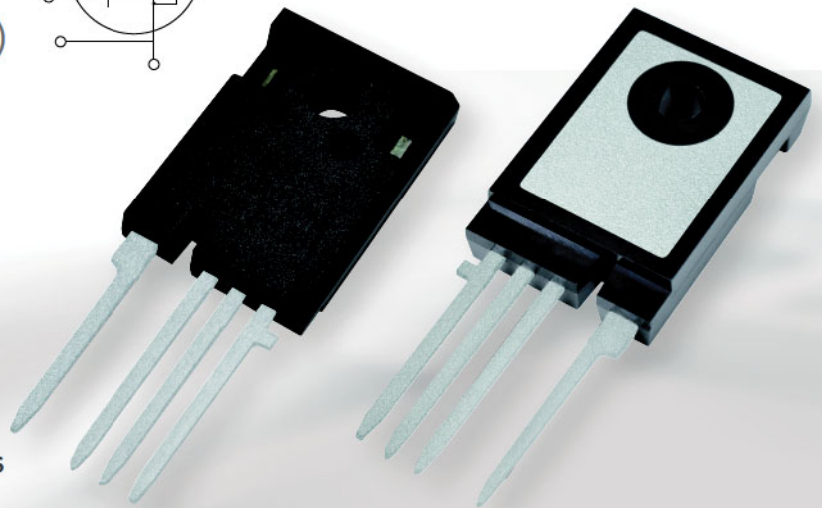
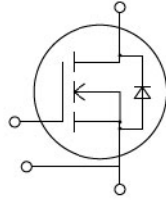

Applications

- ▶ Industrial Inverter
- ▶ Uninterruptible Power Supply
- ▶ EV Battery Charger
- ▶ Various Switching Mode Power Supplies

UL Compliant 
 UL File No.E76102

Features

- Isolated package with good heat dissipation. ($R_{th(j-c)}=0.22^{\circ}\text{C}/\text{W}$ Typ)
- Adopts a 4-pin structure for high-speed switching and low loss.
- Low ON Resistance. ($15\text{m}\Omega$ Typ. $T_j=150^{\circ}\text{C}$)
- Mitigates energy loss with little change in on-resistance even during high-temperature operation.
- Gate characteristics that provide high noise immunity at high frequency operation. ($V_{GS(th)} : 4.0\text{V}$ Typ.)
- Top-level short-circuit resistance.

Superior performance with DioMOS* technologies

*SiC MOSFET (DioMOS) with reflux diode function developed by Panasonic is mounted.
 Low RDS(on) due to maximization of package space.

Low ON resistance

ON Resistance temperature characteristics (normalized at 25 °C)

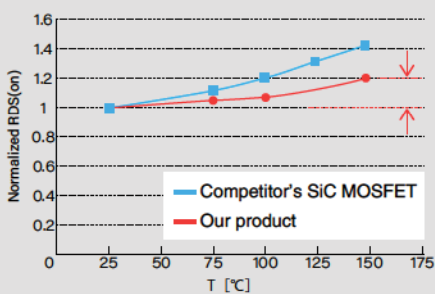

Embedded FWD

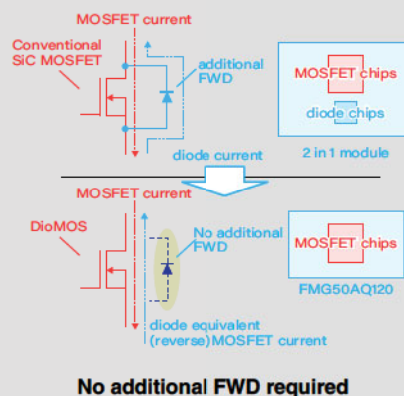

Supports high current density

The double side solder bonding reduces wire resistance and increases robustness, bringing out SiC chips performance with a current density four times greater than in conventional products.

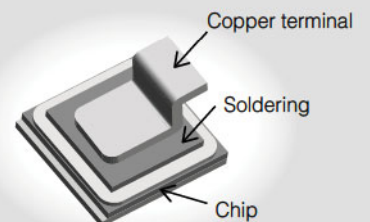

SiC MOSFET (TO-247-4L) FMG50AQ120N6

Maximum Ratings

T_J=25°C unless otherwise specified

Item	Symbol	Unit	Rating	Conditions
Drain-Source Voltage	V _{DSS}	V	1200	
Continuous Drain Current	I _D	A	50	V _{GS} =20V, T _c =108°C, DC
Total Power Dissipation	P _{tot}	W	440	T _c =25°C
Operating Junction Temperature	T _J	°C	-40 ~ +150	
Isolation Voltage	V _{iso}	V	2500	AC, RMS, 1min, Main Terminal to Case

Electrical Characteristics

T_J=25°C unless otherwise specified

Item	Symbol	Unit	Rating			Conditions
			Min.	Typ.	Max.	
On-State Resistance	R _{DS(on)}	mΩ		13.0	28.0	V _{GS} =20V, I _D =50A
				15.0	30.0	V _{GS} =20V, I _D =50A, T _J =150°C
Drain Cut-off Current	I _{DSS}	μA			100	V _D =1200V, V _{GS} =0V
Gate-Source Threshold Voltage	V _{GS(th)}	V	3	4	5	V _D =10V, I _D =1.5mA
Gate-Source Leakage Current	I _{GSS}	nA			100	V _{GS} =20V, V _{DS} =0V
Thermal Resistance	R _{th(j-c)}	°C/W		0.22	0.28	Junction to Case

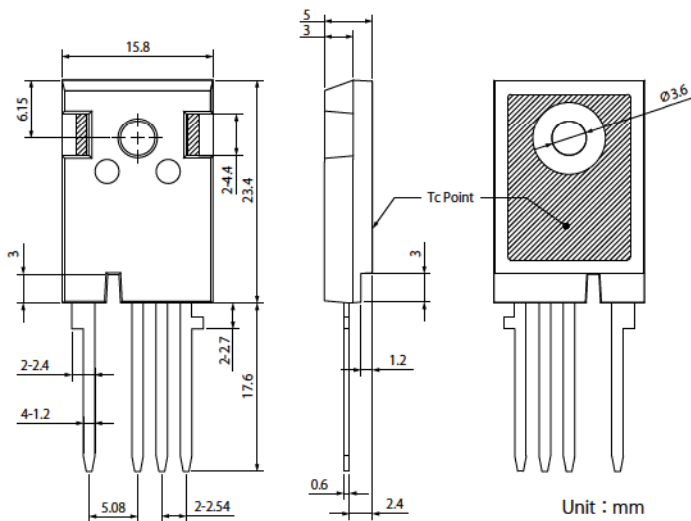

Other Products

SiC MOSFET Module

Highly reliable "TechnoBlock" package
FCA150AC120 / FCA100AC120 (150A / 100A 1200V)

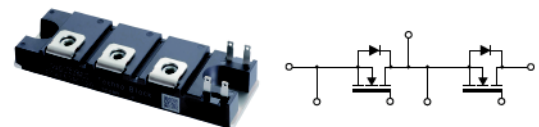

Please inquire about the gate drive unit.

- SanRex and TechnoBlock are trademarks or registered trademarks of Sansha Electric Manufacturing Co., Ltd.
- Appearance and specifications of products are subject to change without notice for improvement reasons.

Sansha Electric Manufacturing Co., Ltd.
<https://www.sansha.co.jp/>



Headquarters / branches / sales offices

Headquarters (International Sales Department)

TEL: +81-6-6325-6621 FAX: +81-6-6325-0503

Tokyo Branch

TEL: +81-3-3834-1700 FAX: +81-3-3834-1702

Chubu Sales Office

TEL: +81-52-955-5600 FAX: +81-52-955-5650

Kyushu Sales Office

TEL: +81-92-431-7586 FAX: +81-92-474-9643

Hokuriku Office

TEL: +81-76-293-1725 FAX: +81-76-293-1881

Plants

Shiga Plant

TEL: +81-77-583-8632 FAX: +81-77-583-5395

Okayama Plant

TEL: +81-868-36-3111 FAX: +81-868-36-3065

If you have any questions, please contact the following or our branches or sales offices

Helsinki Branch (Finland)

Atomitie 5C, 00370, Helsinki, Finland
TEL: +358-40-1668580 E-mail: info@sanrex.fi

Seoul Branch (Korea)

#706, 6, Samseong-ro 96-gil, Gangnam-gu Seoul 06168 Korea
TEL: +82-2-552-2803 FAX: +82-2-552-8441

Taipei Branch (Taiwan)

8F-3, No.46, Chung Shan N. Road, Sec. 2, Taipei, Taiwan, R.O.C.
TEL: +886-2-2543-5689 FAX: +886-2-2536-7876

SANSHA SOLUTION SERVICE CO., LTD. (Japan)

TEL: +81-6-6321-0616 FAX: +81-6-6321-0618
Service branches: Osaka, Tokyo, Nagoya, Fukuoka

SUWA SANSHA ELECTRIC CO., LTD. (Japan)

TEL: +81-266-82-6600 FAX: +81-266-73-3322
<https://www.suwa.sansha.co.jp/>

OSAKA DENSO INDUSTRY CO., LTD. (Japan)

TEL: +81-6-6322-4116 FAX: +81-6-6322-3785
<https://osakadenso.jp/>

SANREX CORPORATION (U.S.A.)

TEL: +1-516-625-1313 FAX: +1-516-625-8845
<https://www.sanrex.com/>

SANREX ASIA PACIFIC PTE. LTD. (Singapore)

TEL: +65-6457-8867
<https://www.sanrex.sg/>

SANREX LIMITED (Hong Kong)

TEL: +852-2744-1310 FAX: +852-2785-6009

SANSHA ELECTRIC MFG. (SHANGHAI) CO., LTD. (China)

TEL: +86-21-5868-1058 FAX: +86-21-5868-1056

SANSHA ELECTRIC MFG. (GUANGDONG) CO., LTD. (China)

TEL: +86-757-2733-3688 FAX: +86-757-2783-3547
<http://www.sanrex.cn/>

DONGGUAN EASTERN ELECTRONICS CO., LTD. (China)

TEL: +86-769-8733-8301 FAX: +86-769-8733-8306